

Installation Instructions

Type HVH Horizontal/Vertical Unit Heater



Importado y distribuido en
Chile por:
Safe Energy Spa
www.safe-energy.cl



CHROMALOX
Advanced Thermal Technologies

PF505-10
161-305679-001
May 2019

HVH Horizontal/Vertical Unit Heater

General

Heater Location Instructions:

Arrange units so their discharge air streams:

- A. Are subjected to a minimum of interference from columns, machinery and partitions.
- B. Wipe exposed walls without blowing directly at them.
- C. Are directed away from room occupants in comfort heating.
- D. Are directed along the windward side when installed in a building exposed to a prevailing wind.
- E. See additional mounting limitations in Table D.

Locate thermostat on interior partition walls or posts away from cold drafts, internal heat sources and away from heater discharge air streams.

Small rooms can be heated by one unit heater. Where two walls are exposed, the heater should be mounted as shown in Figure 1.

Large rooms require multi-unit installation. Number and capacity of units will be determined by volume of building and square feet of floor area to be heated. Arrange units to provide perimeter air circulation where each unit supports the air stream from another.

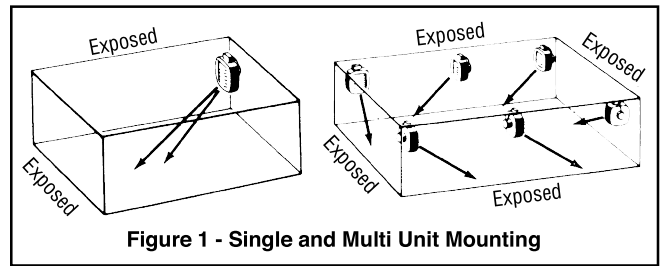

Figure 1 - Single and Multi Unit Mounting

Warning

Failure to understand and follow these installation instructions and the “WARNING” notes therein may result in serious personal injury from electrical shock, or from the heater falling due to faulty installation.

⚠ WARNING

This heater is not intended for use in hazardous atmospheres where flammable vapors, gases, liquids or other combustible atmospheres are present as defined in the National Electric Code. Failure to comply can result in explosion or fire. For these applications see PDS CXH-AEP (PF490).

⚠ WARNING

ELECTRIC SHOCK HAZARD. Disconnect all power before installing or servicing heater. Failure to do so could result in personal injury or property damage. Heater must be installed or serviced by a qualified person in accordance with the National Electrical Code, NFPA 70.

⚠ WARNING

This heater is not intended for use in exposed outdoor, marine, or wash-down environments or in areas where corrosive liquids or fumes exist under normal conditions.

⚠ WARNING

ELECTRIC SHOCK HAZARD. Any installation involving electric heaters must be performed by a qualified person and must be effectively grounded in accordance with the National Electrical Code to eliminate shock hazard.

Do not mount mercury type thermostat directly on unit. Vibration could cause heater to malfunction.

The heater must be mounted at least 7' above the floor to prevent accidental contact with the heating elements or fan blade which could cause injury.

Keep at least 5' clearance in front of the heater. Refer to Table D for side, top and back clearance requirements.

The ceiling mounting structure and the anchoring provisions must be of sufficient strength to support the combined weight of the heater and mounting bracket. (Refer to Table B for weights of heater and bracket.)

The wall or mounting surface, and the anchoring provisions must be capable of supporting the combined weight of the heater and mounting brackets cantilevered from the mounting surface. (Refer to Table B for weights of heater and brackets and for cantilevered force expressed in foot-pounds.)

Fan blade rotation must be checked. If airflow is not moving out through the louvers, interchange any two of the three customer power leads on three-phase units only.

Table B – Weights of Heater & Bracket

Model	WEIGHT (Lbs.) Heater and Brackets		
	Ceiling Weight	Wall	
		Weight	Ft.-Lbs.
HVH-02 to HVH-05	27	25-1/2	48
HVH-15 to HVH-20	55	67-1/4	112
HVH-25, 30, 35	108	105	126.3
HVH-40, 45, 50	118	115	138.4

Specifications – Table A

Model	Volts	Watts	Phase	Amps	BTU	A Height	B Width	C Depth	Std. Contactor Rating (Qty.)	Wiring Dia. Figure
HVH-02-81	208	2,667	1	12.8	8,850	16-1/8	13	10	—	10
HVH-02-21	208/240	2000/2,667	1	11.1*	8,850	16-1/8	13	10	—	10
HVH-02-71	277	2,667	1	9.6	8,850	16-1/8	13	10	—	10
HVH-04-81†	208	4,000	1	19.2	13,661	16-1/8	13	10	—	10
HVH-04-83†	208	4,000	3	11.2	13,661	16-1/8	13	10	30A (1)	12
HVH-04-21†	208/240	3,000/4,000	1	16.7*	13,661	16-1/8	13	10	—	10
HVH-04-23†	208/240	3,000/4,000	3	9.6*	13,661	16-1/8	13	10	30A (1)	12
HVH-04-71	277	4,000	1	14.5	13,661	16-1/8	13	10	—	10
HVH-04-43	480	4,000	3	4.8	13,661	16-1/8	13	10	30A (1)	11
HVH-05-81†	208	5,000	1	24.0	17,076	16-1/8	13	10	—	10
HVH-05-83†	208	5,000	3	13.8	17,076	16-1/8	13	10	30A (1)	12
HVH-05-21†	208/240	3,750/5,000	1	20.8*	17,076	16-1/8	13	10	—	10
HVH-05-23†	208/240	3,750/5,000	3	12.1*	17,076	16-1/8	13	10	30A (1)	12
HVH-05-71	277	5,000	1	18.2	17,076	16-1/8	13	10	—	10
HVH-05-43	480	5,000	3	6.0	17,076	16-1/8	13	10	30A (1)	13
HVH-07-81†	208	7,500	1	36.1	25,598	20-5/8	17-1/8	12-3/4	50A (1)	12
HVH-07-83	208	7,500	3	20.9	25,598	20-5/8	17-1/8	12-3/4	30A (1)	12
HVH-07-21†	208/240	5,625/7,500	1	31.1*	25,598	20-5/8	17-1/8	12-3/4	30A (1)	12
HVH-07-23	208/240	5,625/7,500	3	18.1*	25,598	20-5/8	17-1/8	12-3/4	30A (1)	12
HVH-07-71	277	7,500	1	27.2	25,598	20-5/8	17-1/8	12-3/4	30A (1)	12
HVH-07-43	480	7,500	3	9.0	25,598	20-5/8	17-1/8	12-3/4	30A (1)	13
HVH-10-81†	208	10,000	1	48.0	34,130	20-5/8	17-1/8	12-3/4	50A (1)	12
HVH-10-83	208	10,000	3	27.8	34,130	20-5/8	17-1/8	12-3/4	30A (1)	12
HVH-10-21†	208/240	7,500/10,000	1	41.7*	34,130	20-5/8	17-1/8	12-3/4	30A (1)	12
HVH-10-23	208/240	7,500/10,000	3	24.0*	34,130	20-5/8	17-1/8	12-3/4	30A (1)	12
HVH-10-43	480	10,000	3	12.0	34,130	20-5/8	17-1/8	12-3/4	30A (1)	13
HVH-12-83	208	12,500	3	34.8	42,663	20-5/8	17-1/8	12-3/4	50A (1)	12
HVH-12-23	208/240	9,375/12,500	3	30.1*	42,663	20-5/8	17-1/8	12-3/4	50A (1)	12
HVH-12-43	480	12,500	3	15.1	42,663	20-5/8	17-1/8	12-3/4	30A (1)	13
HVH-15-83	208	15,000	3	41.8	51,195	20-5/8	17-1/8	12-3/4	50A (1)	12
HVH-15-23	208/240	11,250/13,000	3	36.2*	51,195	20-5/8	17-1/8	12-3/4	50A (1)	12
HVH-15-43	480	15,000	3	18.1	51,195	20-5/8	17-1/8	12-3/4	30A (1)	13
HVH-20-23	208/240	14,758/19,500	3	47.0	66,534	20-5/8	17-1/8	14-1/16	50A (2)	15
HVH-20-43	480	19,500	3	23.5	66,534	20-5/8	17-1/8	14-1/16	50A (1)	14
HVH-20-63	600	19,500	3	18.8	66,534	20-5/8	17-1/8	14-1/16	50A (1)	14
HVH-25-23	208/240	18,720/24,900	3	60.0	84,959	29-3/16	26-1/16	14-5/8	50A (2)	15
HVH-25-43	480	25,000	3	30.2	85,300	29-3/16	26-1/16	14-5/8	50A (1)	14
HVH-25-63	600	25,000	3	24.1	85,300	29-3/16	26-1/16	14-5/8	50A (1)	14
HVH-30-23	208/240	22,400/29,900	3	72.1	102,019	29-3/16	26-1/16	14-5/8	50A (2)	15
HVH-30-43	480	30,000	3	36.2	102,360	29-3/16	26-1/16	14-5/8	50A (1)	14
HVH-30-63	600	30,000	3	29	102,360	29-3/16	26-1/16	14-5/8	50A (1)	14
HVH-35-23	208/240	25,600/34,000	3	81.9	116,008	29-3/16	26-1/16	14-5/8	50A (3)	15
HVH-35-43	480	34,000	3	41	116,008	29-3/16	26-1/16	14-5/8	50A (1)	14
HVH-35-63	600	34,200	3	33	116,690	29-3/16	26-1/16	14-5/8	50A (1)	14
HVH-40-23	208/240	28,000/37,400	3	90.1	127,609	29-3/16	26-1/16	14-5/8	50A (3)	16
HVH-40-43	480	37,400	3	45.1	127,609	29-3/16	26-1/16	14-5/8	50A (1)	14
HVH-40-63	600	37,500	3	36.2	127,950	29-3/16	26-1/16	14-5/8	50A (1)	14
HVH-45-23	208/240	33,700/44,800	3	107.9	152,858	29-3/16	26-1/16	14-5/8	50A (3)	16
HVH-45-43	480	44,800	3	54	152,858	29-3/16	26-1/16	14-5/8	50A (2)	15
HVH-45-63	600	45,200	3	43.6	154,222	29-3/16	26-1/16	14-5/8	50A (1)	14
HVH-50-23	208/240	38,400/50,000	3	123.1	174,353	29-3/16	26-1/16	14-5/8	50A (3)	16
HVH-50-43	480	50,000	3	61.6	174,353	29-3/16	26-1/16	14-5/8	50A (2)	15
HVH-50-63	600	50,000	3	49.5	175,036	29-3/16	26-1/16	14-5/8	50A (2)	15

*Note: 208V amperage is 86% of 240V value. † These models can be field changed from single phase to three phase or three phase to single phase.

Installation

NOTICE – These heaters are designed for wall and ceiling mount.

Other modes of mounting void factory warranty.

Vertical Air Flow

1. Height above floor
 - A. It is recommended that the heater only be used with ceiling heights of 12 feet or greater. Minimum spacing to ceiling is 6 inches, use 3/8-18" thread stock (supplied by others) as shown in Figure 3.
 - B. Minimum mounting height is 10 feet from floor to bottom of heater.
2. Spacing to walls.
 - A. Side of case to wall 6". Top or bottom of case to back wall is 10-1/4" (HVH-02 to HVH-05), 13" (HVH-15 to HVH-20) and 15-1/2" (HVH-25 to HVH-50).

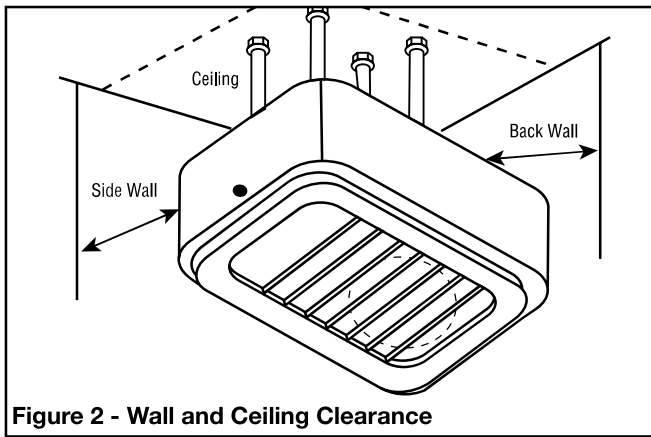

Figure 2 - Wall and Ceiling Clearance

CEILING (Vertical Airflow):

- A. The heater can be rod mounted to the ceiling by installing four (4) threaded mounting rods in the threaded holes located on the top of the heater as shown in Figure 3. (Refer to Table C for mounting rod thread size.)

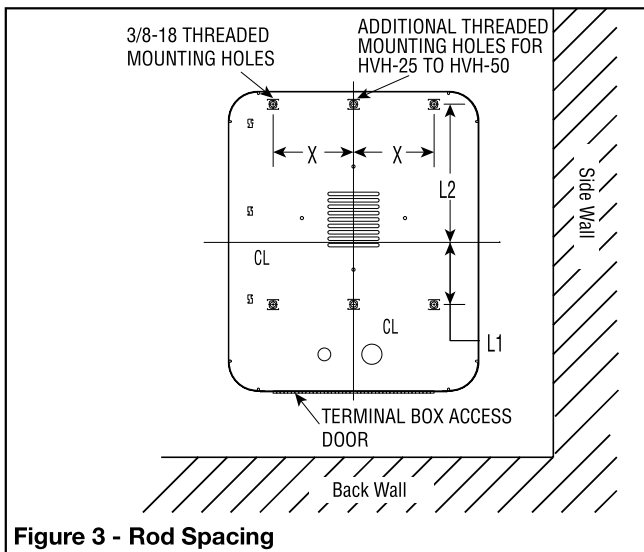

Figure 3 - Rod Spacing

- B. Securely attach the four (4) mounting rods to the ceiling. (Refer to Table D for wall and ceiling clearances, and Figure 2 for mounting spacing specifications.)

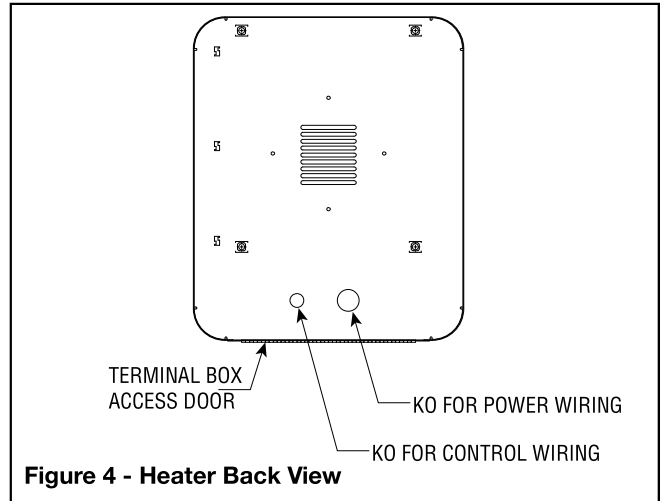

Figure 4 - Heater Back View

Knockout Sizes		
HVH-02 - 05	1/2"	3/4" (1)
HVH-07 - 20	1/2"	1" (1)
HVH-25 - 50	1-1/4"	2" (1)

Table C — Rod Thread Type and Spacing Dimensions (inches) for Vertical Discharge.

Unit	Rod Thread Type	Dimensions - (In.)		
		L1	L2	X
2-5 kW	3/8-16	2-7/8	7-1/8	3-3/4
7-1/2 - 20 kW	3/8-16	4-5/16	9-3/8	5-1/2
25 - 50 kW	3/8-16	8-15/16	14	9-15/16

Table D — Clearance Requirements (Vertical Discharge)

Model	Mounting Limitations (In.)		
	Back to Wall	Side to Wall	Top to Ceiling
HVH-02 thru HVH-05	10-1/4	6	6
HVH-07 thru HVH-20	13	6	6
HVH-25 thru HVH-50	15-1/2	6	6

Horizontal Air Flow

1. Height above floor
 - A. In areas where ceiling height is more that 12 feet, recommended mounting height is approximately 10 feet to underside of heater.
 - B. For ceiling heights of 12 feet or less, maximum mounting height is determined by the use of the mounting bracket offered for these heaters. Minimum spacing to ceiling is 7-3/4". (See Figure 5)
 - C. In either case, the minimum mounting height is 7 feet from floor to bottom of heater.
2. Spacing to adjacent walls.
 - A. Rear of case to back wall 2" minimum.
 - B. Side of case to side wall 6" minimum.



CEILING – Horizontal Airflow (See Figure 5):

The ceiling mounting bracket is fastened to the top of the heater using the four (4) bolts supplied with the mounting bracket. The bracket is then mounted to the ceiling using a 5/8” bolt (by others).

WALL – Horizontal Airflow (See Figure 6):

Wall mounting requires the HVW Bracket Kit. Follow figure 6 to properly install the bracket adapter and swivel bracket. The bracket kits include all hardware

require to install bracket to heater only. Complete installation requires additional bolts (not supplied) to secure to wall. HVH heaters up to 20kW require 4 x 3/8” bolts. Heaters above 20kW include a larger anti-sway bracket that requires an additional two bolts for a total of 6 x 3/8” bolts.

The heater may be rotated to discharge in the desired direction. Open and adjust louvers to desired position. See Figure 5 and 6 for additional mounting details.

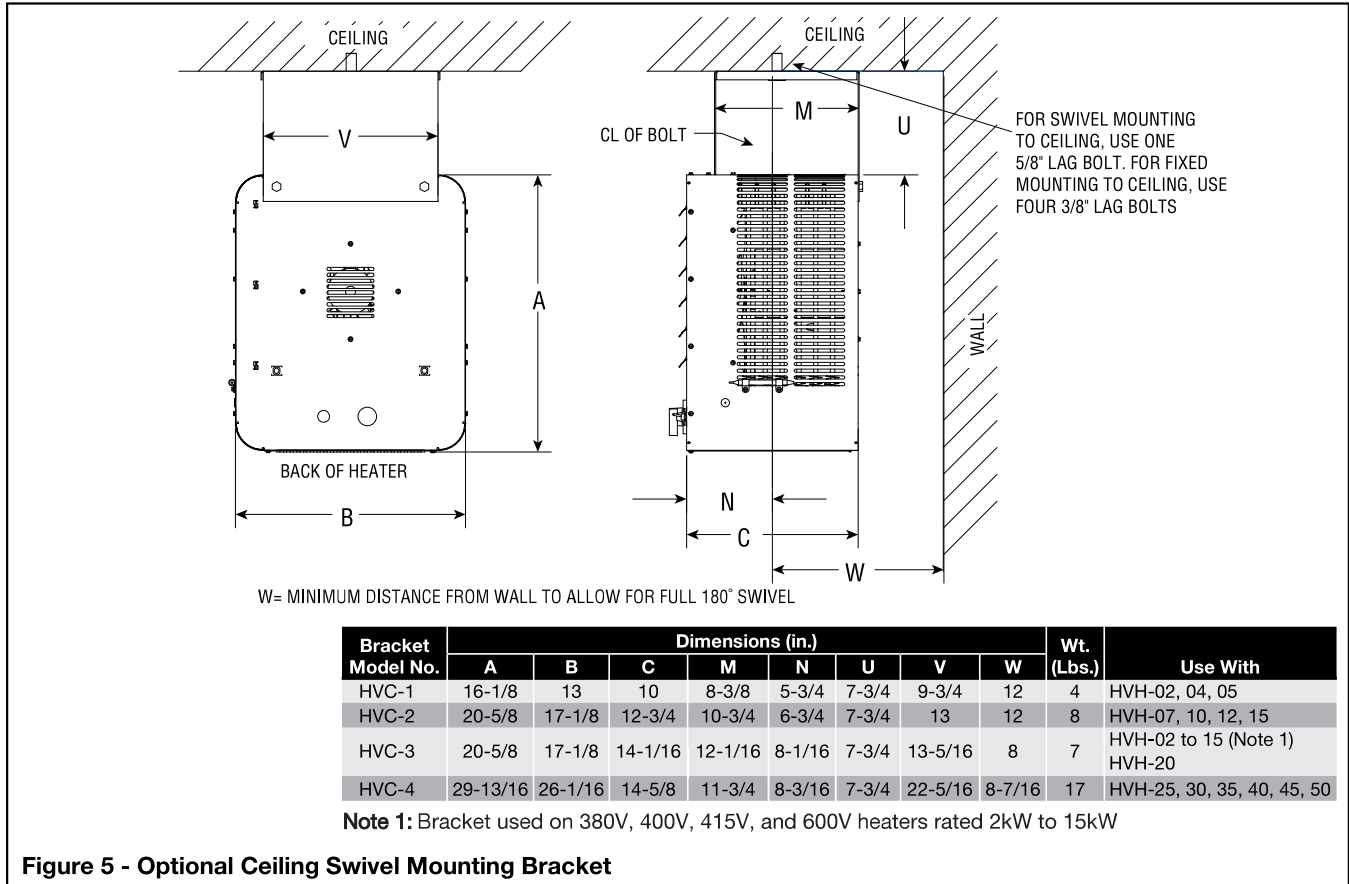
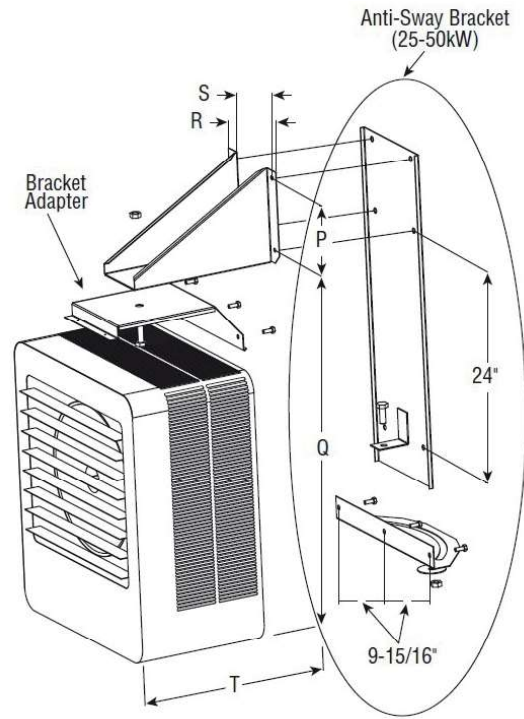

Figure 5 - Optional Ceiling Swivel Mounting Bracket



Importado y distribuido en Chile por:
Safe Energy Spa
www.safe-energy.cl



Bracket Model No.	Dimensions (in.)					Bracket Wt. (Lbs.)	Use With
	P	Q	R	S	T		
HVW1	16-1/16	18-7/8	7	5	17-5/8	3-3/4	HVH-02, 04, 05
HVW2	16-1/16	23-1/4	7	5	18-5/8	6-1/2	HVH-07, 10, 12, 15
HVW3	6	23-7/16	6-7/8	4-15/16	20-1/16	9	HVH-02 to 15 (Note 1) HVH-20
HVW4	8	32-13/16	10-3/8	8-1/2	22-7/16	14	HVH-25, 30, 35, 40, 45, 50

Note 1: Bracket used on 380V, 400V, 415V, and 600V heaters rated 2kW to 15kW

Figure 6 - Optional Wall Swivel Mounting Bracket

Wiring

⚠ WARNING

ELECTRIC SHOCK HAZARD. Be sure electricity is turned off at main switch first before wiring. Any installation involving electric heaters must be effectively grounded in accordance with the National Electrical Code to eliminate shock hazard.

1. Use heater only on the voltage and frequency specified on the nameplate.
2. All wiring should be done in accordance with local codes and the National Electrical Code by a qualified person as defined in the NEC.
3. Two knockouts are provided on the back of the heater for wire entry. See Fig. 4 for location of knockouts.
4. Branch circuit wire for connection to heater must be at least 60°C wire.
5. The bottom access door is hinged. There are two screws that must be removed to gain access (Fig. 3).
6. A ground wire or ground lug is provided near the

power connection point (ground Wire on HVH-02 to HVH-20 and ground lug on HVH-25 to HVH-50).

7. Terminals on contactor or on line voltage terminal block are supplied to be connected to accept the correct size power supply wire. Copper rated at 600V and 60°C is satisfactory for the heater branch circuit.
8. Electrical accessories, either kits or factory-installed options, are shown connected by a dash line on the heater wiring diagram.
9. Wiring connections are to be made on designated wire leads as shown in the wiring diagrams located inside the access door.
10. Louver adjustment (Do not attempt to adjust while heater is operational): Louvers have been preset at factory with the minimum open angle. Decreasing the 45° angle may result in high temperatures and functioning of the over temperature control. To increase the opening angle, grasp the left end of louver with the left hand using the index finger and thumb. Grasp right end of louver with right hand in the same manner. Twist louver to the desired position.

⚠ WARNING

ELECTRIC SHOCK HAZARD. Be sure electricity is turned off at main switch first before wiring. Any installation involving electric heaters must be effectively grounded in accordance with the National Electrical Code to eliminate shock hazard.

1. Use heater only on the voltage and frequency specified on the nameplate.
2. All wiring should be done in accordance with local codes and the National Electrical Code by a qualified person as defined in the NEC.
3. Two knockouts are provided on the back of the heater for wire entry. See Fig. 4 for location of knockouts.
4. Branch circuit wire for connection to heater must be at least 60°C wire.
5. The bottom access door is hinged. There are two screws that must be removed to gain access (Fig. 3).
6. A ground wire or ground lug is provided near the power connection point (ground Wire on HVH-02 to HVH-20 and ground lug on HVH-25 to HVH-50).
7. Terminals on contactor or on line voltage terminal block are supplied to be connected to accept the correct size power supply wire. Copper rated at 600V and 60°C is satisfactory for the heater branch circuit.
8. Electrical accessories, either kits or factory-installed options, are shown connected by a dash line on the heater wiring diagram.
9. Wiring connections are to be made on designated wire leads as shown in the wiring diagrams located inside the access door.
10. Louver adjustment (Do not attempt to adjust while heater is operational): Louvers have been preset at factory with the minimum open angle. Decreasing the 45° angle may result in high temperatures and functioning of the over temperature control. To increase the opening angle, grasp the left end of louver with the left hand using the index finger and thumb. Grasp right end of louver with right hand in the same manner. Twist louver to the desired position.

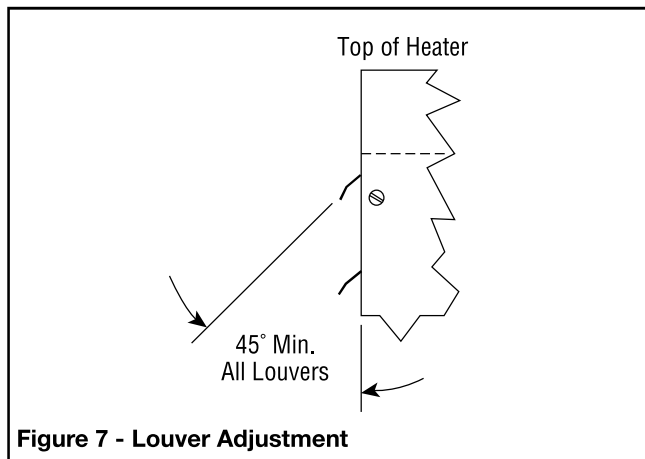

POWER DISCONNECT SWITCH

(Available as a kit or factory installed option). This switch disconnects the power to the power leads when the handle is turned to its off position. Refer to Instruction Sheet PF207.

1. Use copper conductor supply wire only when connecting to the power line. (See Figure 8.)
2. Connection to the switch pigtails should be made with compression connectors and the joint should be then well insulated.
3. Consult the local wiring code in your area.

SUMMER FAN SWITCH - Refer to Instruction sheet PF205 without relay, PF206 with relay.

(MOUNTED ON FRONT OF HEATER). When the switch handle is pointing toward the Summer (Fan ON) position, the fan will run continuously. When the switch handle is pointing toward the WINTER (HEAT) position, the fan will run only when the heating elements are hot.

REMOTE SUMMER FAN SWITCH

(MANUAL SWITCH-LINE VOLTAGE). The wall switch is packed in the wiring compartment. The remote fan switch is mounted external and remote from the HVH unit heater. The voltage of the remote fan switch is the same as the supply voltage to the HVH heater.

1. Use 14 gauge copper, NEC Class 1, 600V rated insulated wire. Wiring must meet all Local and NEC requirements for 480-volt service.
2. Install the remote fan switch in standard wall box in any convenient location that is protected from traffic or other accidental damage.
3. Connect the 14 gauge copper field wire to the switch lead wires with suitable connectors.

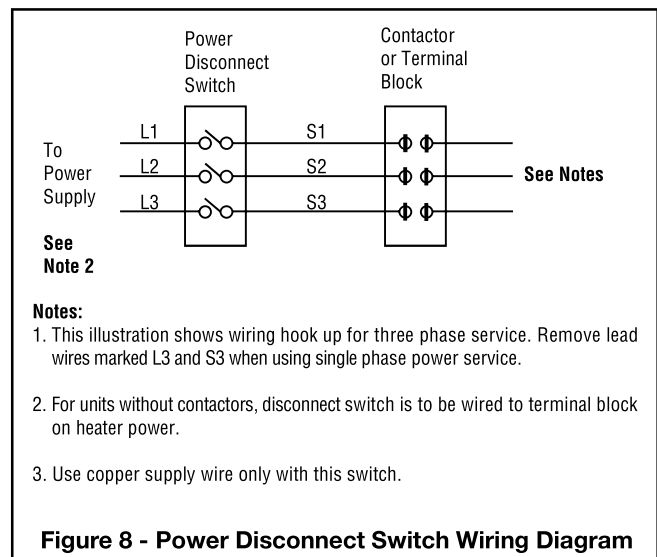

Importado y distribuido en Chile por:
Safe Energy Spa
www.safe-energy.cl

REMOTE FAN SWITCH

480V + Heaters require an additional fan relay. (Available as a kit or factory installed option and standard on heaters 20kW and above).

The wall switch is packed in the wiring compartment.

1. Use 18 gauge (min.) NEC Class 1, 600V wiring that meets all Local and NEC requirements.
2. Install the wall switch in a standard wall box in any convenient location that is protected from traffic or other accidental damage.
3. Connect the field wire to the switch lead wires with suitable connectors.

OPTIONAL THERMOSTAT (HVH-TK) Refer to Instruction Sheet PF204.

Heaters can be equipped with an optional thermostat of the Bulb and Capillary type for automatic temperature control (Figure 8). The thermostat controls the heating elements and fan simultaneously to achieve set temperature.

The "Lo" setting of the thermostat is approximately 40°F, and the "Hi" setting is approximately 90°F.

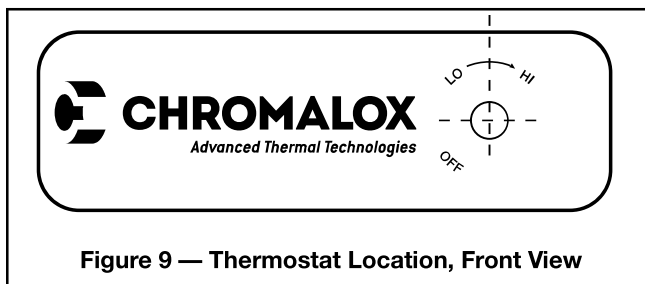

Figure 9 — Thermostat Location, Front View

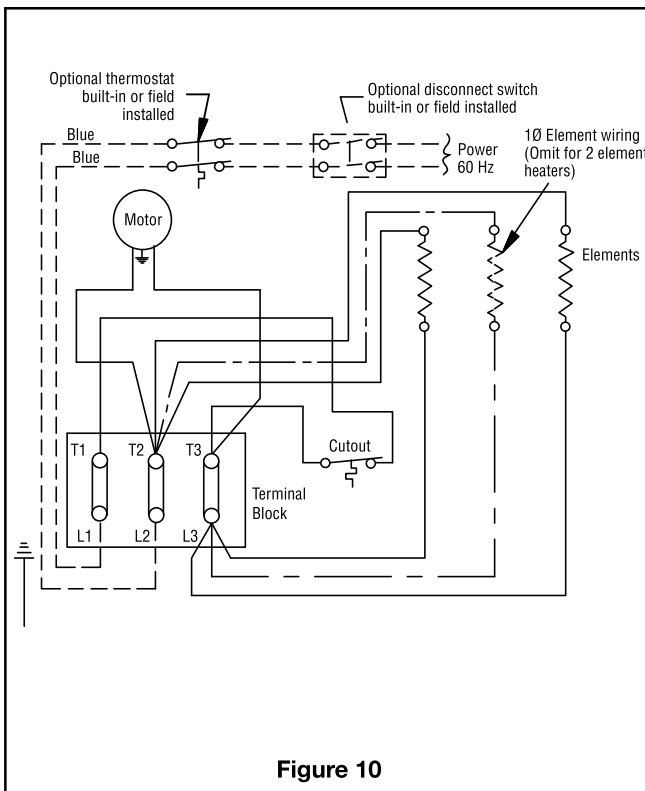

Figure 10

CONTROL VOLTAGE WIRING — EXTERNAL REMOTE THERMOSTATS AND FAN SWITCHES

⚠ WARNING

ELECTRIC SHOCK HAZARD. Be sure electricity is turned off at main switch first before wiring. Any installation involving electric heaters must be effectively grounded in accordance with the National Electrical Code to eliminate shock hazard.

1. Use 600 volt, NEC Class 1 insulated wiring with a minimum gage of 18 for thermostats and minimum gauge of 14 for line voltage motor switch (remote fan switch without relay).
2. The thermostat should be located in the area to be heated on an inside wall. The thermostat should not be exposed to drafts, sunlight, radiation from hot objects, or in a direct line with the discharge from the unit heater.
3. Install the thermostat approximately 5 feet above the floor line.
4. Install the remote fan switch in any convenient location that is protected from traffic or likely accidental damage.
5. Internal optional controls are shown on the unit heater wiring diagrams by a dash line.

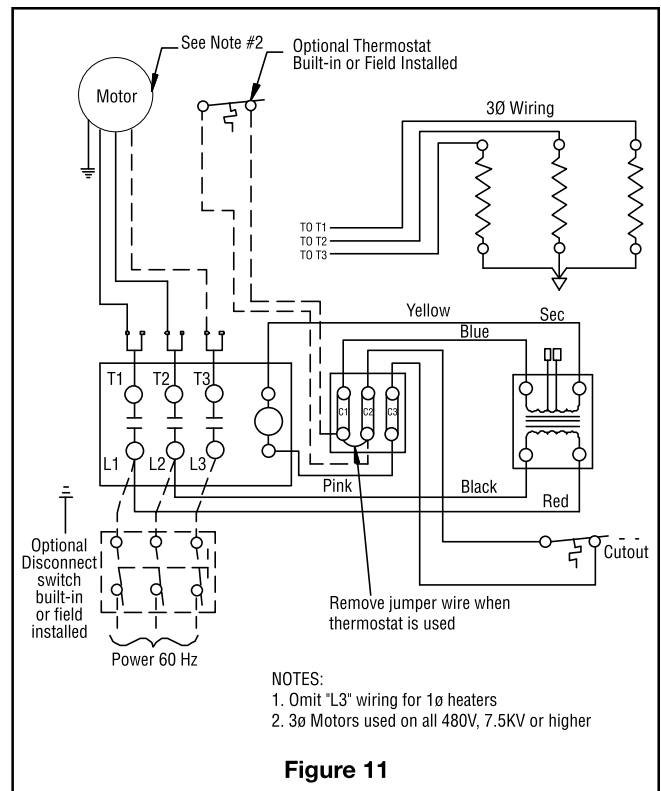

- NOTES:
1. Omit "L3" wiring for 1Ø heaters
 2. 3Ø Motors used on all 480V, 7.5KV or higher

Figure 11

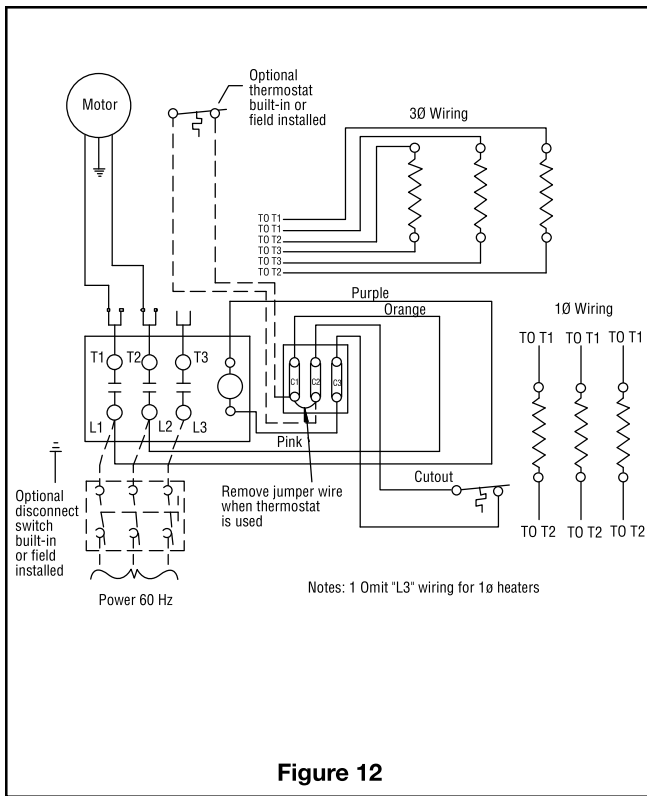

Figure 12

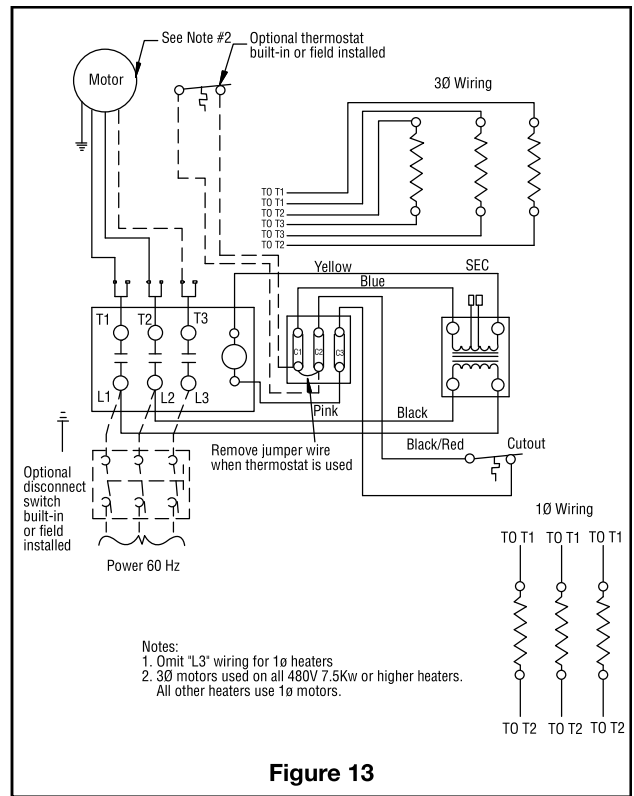

Figure 13

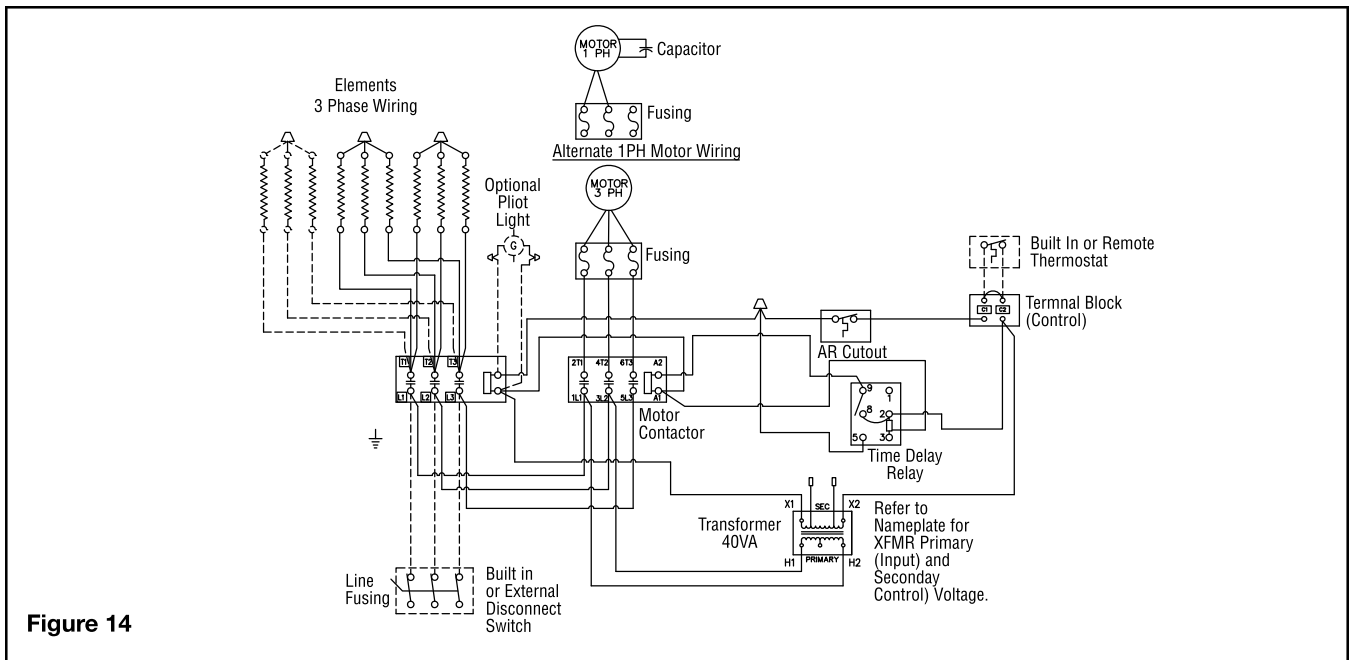
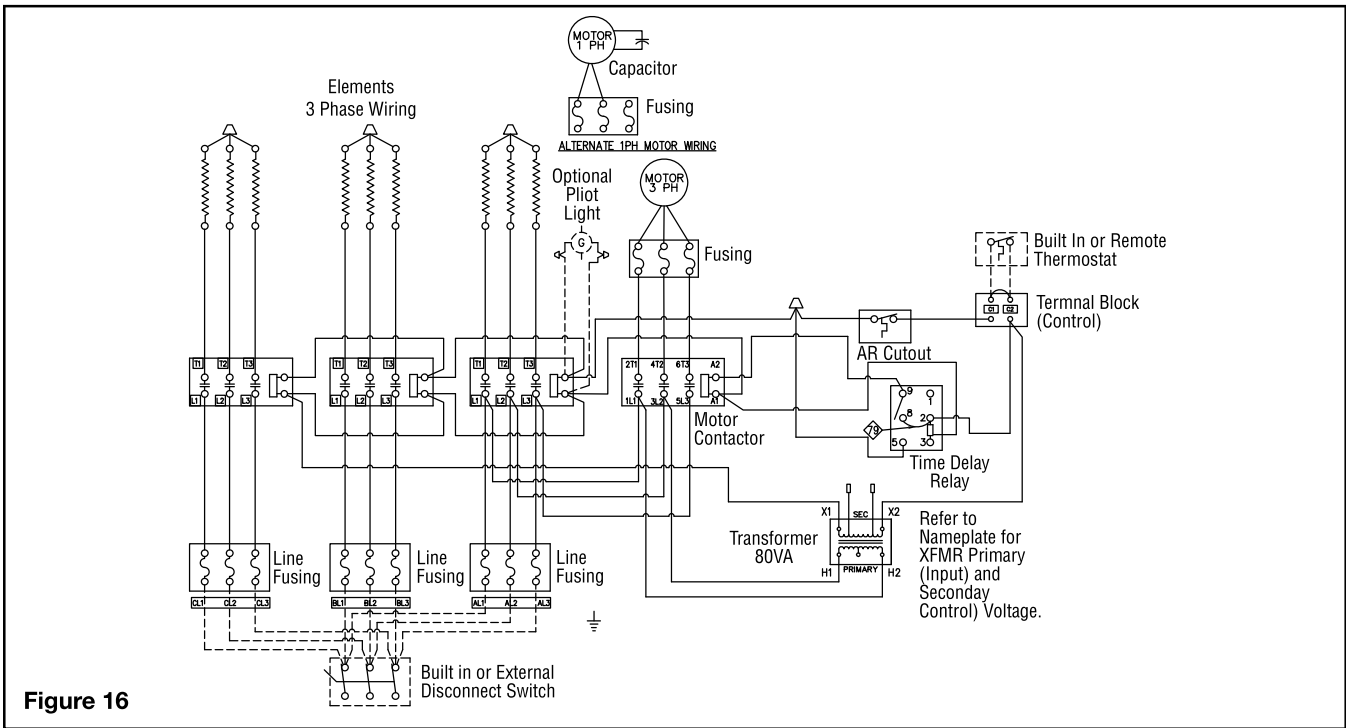
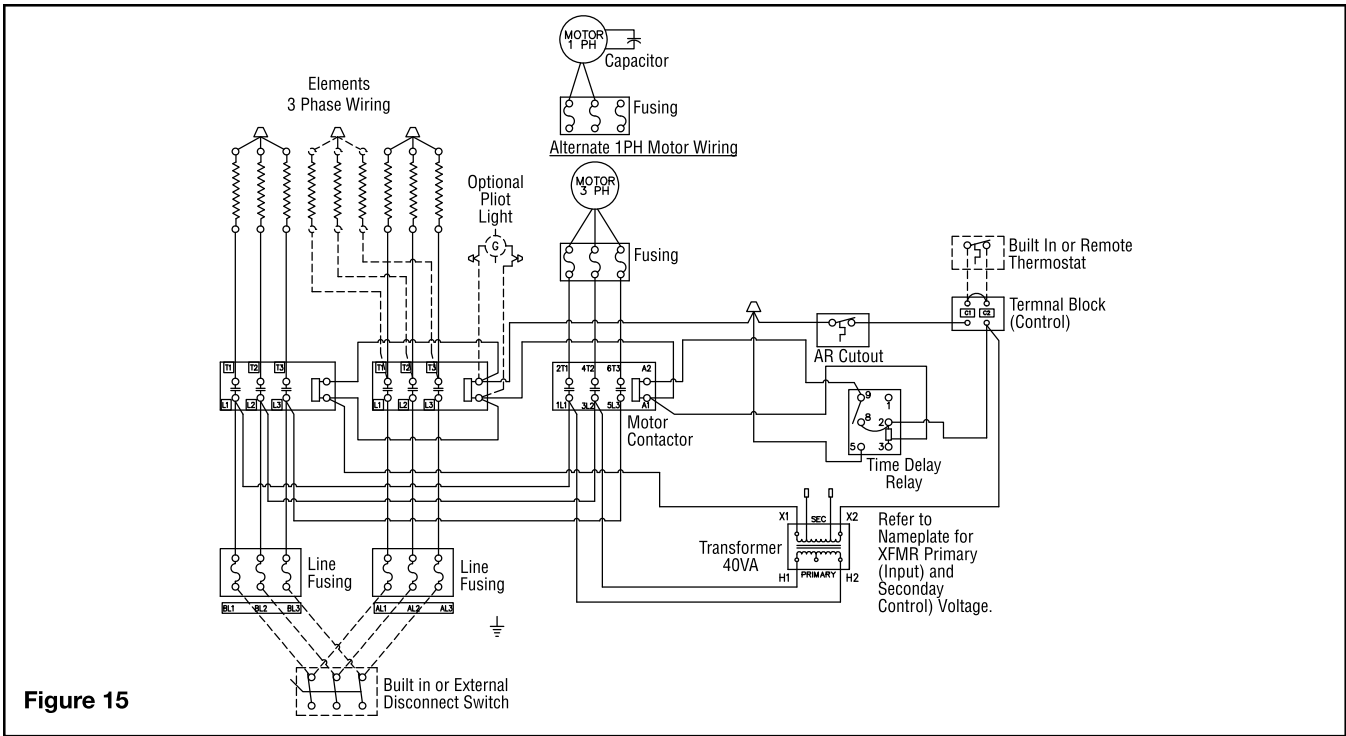

Figure 14



Operating Heater

1. Once power is supplied to unit, both the fan motor and heating elements will immediately turn on.
2. When operating without thermostat control, the only way to manually turn unit on or off is via remote/integral disconnect switch or circuit breaker.
3. All units are equipped with an automatic temperature cutout switch. As such, units not equipped with a thermostat may automatically shut off to protect fan motor and heating elements.
4. Unit may also be provided with an optional fan delay (standard on units above 20kW) which enables the fan to run for approximately one minute after heating elements are turned off.



Operating Integral Mechanical Thermostat

1. Thermostat controlled units will turn on and off based on the set point of the thermostat.
2. To increase the temperature set-point, turn the thermostat dial in the clockwise direction (Hi).
3. To decrease the temperature set-point, turn the dial in the counterclockwise direction (Low).
4. To turn the unit off, turn the dial in the counterclockwise direction until it stops. You should be able to hear the contactors de-energizing.

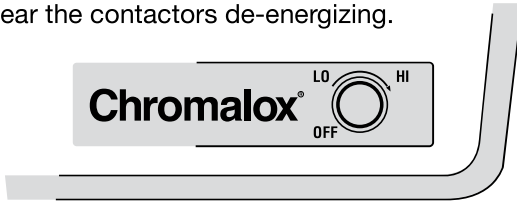

Operating Integral Summer Fan Switch

1. Units equipped with fan switch can operate in two modes: summer and winter. When operating in summer mode, heating elements will not operate (only fan). When operating in winter mode, both fan motor and heating elements will operate.
2. To operate the unit in summer mode (Fan Only), flip the toggle switch into the upward position.
3. To operate the unit in the winter mode (Fan + Heat), flip the toggle switch into the downward position.



Operating Integral Disconnect Switch

1. Chromalox HVH models equipped with an integral disconnect allow for power to be locally isolated from the heater.
2. The disconnect switch used on HVH models is a rotary style disconnect, designed for easy on/off operation.
3. To disconnect power from the HVH heater simply turn the rotary dial in the counterclockwise direction so it is pointing at "0".



Maintenance and Troubleshooting

⚠ WARNING

ELECTRIC SHOCK HAZARD. Disconnect all power before installing or servicing heater. Failure to do so could result in personal injury or property damage. Heater must be installed or serviced by a qualified person in accordance with the National Electrical Code, NFPA 70.

Preventative Maintenance

To optimize performance and prevent downtime, it is recommended that preventative maintenance be performed on Chromalox model HVH heaters. Recommended preventative maintenance includes:

1. Inspect and if necessary tighten fasteners attaching mounting bracket to unit and wall/ceiling.

2. Inspect fan blade to make sure it is securely fastened to motor shaft. Check set screw on collar to ensure it is tightened to recommended torque of 165 inch-lbs.
3. Inspect fasteners on motor mount as it may be possible for vibration to cause loosening.
4. Inspect inlet grills and outlet louvers and remove any airborne debris that may have become stuck.
5. Inspect control panel for any loose wire connections and replace frayed or damaged wires.
6. It is recommended that the fan motor be replaced after 5 years or 10,000 hours of operation (see fan motor replacement instructions).

Troubleshooting

Problem	Probable Cause	Solution
Unit will not turn on	Thermostat set point too low.	Turn dial in clockwise direction to increase temperature set point.
	Improper or loose wire connections.	Check control and power circuit to make sure they are wired properly and for any loose wire connections.
	Disconnect switch in off position.	Make sure disconnect switch is in “on” position by turning it in the clockwise direction.
	Tripped circuit breaker or blown fusing (located remotely from unit).	Check to see if circuit breaker has been tripped or replace fusing.
	Blown internal fusing (located on units rated above 48 amps).	Replace fusing as needed.
Unit not producing heat	Thermostat set point too low.	Turn dial in clockwise direction to increase temperature set point.
	Summer fan switch is set to “Summer” mode or wired incorrectly	If a summer fan switch is installed, check to make sure it is switched to the “Winter” setting. Check to make sure wires on switch are not reversed.
	Element Failure	Element failure can be confirmed by performing a continuity test or by measuring the elements resistance.
Unit turns off suddenly or cycles off before reaching temperature set point	Low airflow is causing automatic reset temperature cutout on elements to activate.	<p>There are several reasons for low airflow and most of them can be easily corrected.</p> <ul style="list-style-type: none"> • The first reason for low airflow is stratification of the air in a room. This can cause the ambient temperature around the heater to exceed the maximum rated operating temperature. The problem can usually be solved by mounting the heater at a lower height. • Low airflow can also be caused by incorrect rotation of the fan. Check that the fan motor is rotating in the counterclockwise direction. • Finally, a common solution for low airflow is to remove any objects located too close to the inlet or outlet.
	Low airflow is causing motor thermal cutout to activate.	

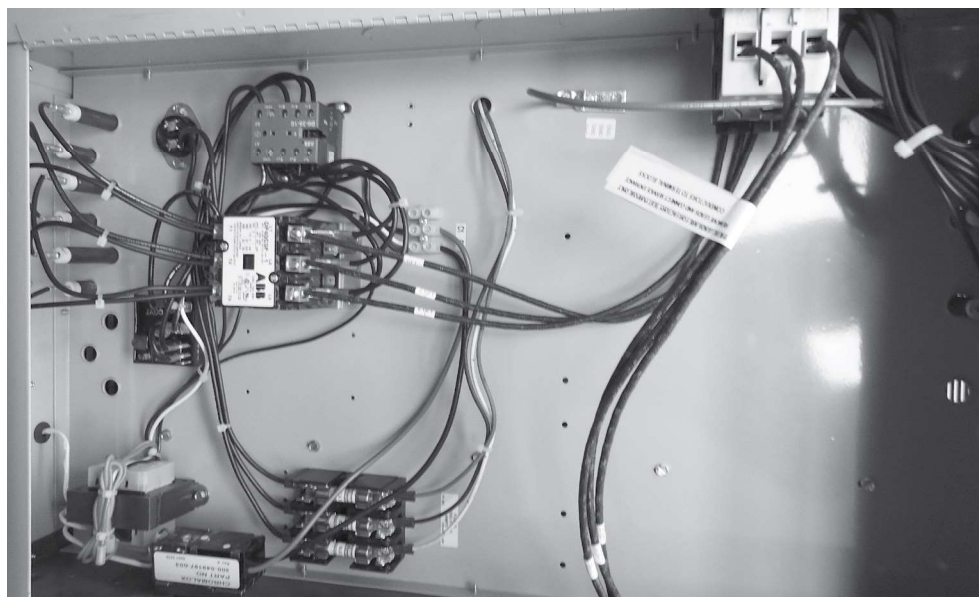

Figure 17:
Control Panel

Renewal Parts Identification (Have heater PN & Model before contacting Chromalox)

Product Type	kW	Volts	Ø	Control Voltage	Integral Thermostat	Integral Disconn. Switch	Fan Only Switch	Time Delay	Power On Pilot Light	Outlet Screen
□□□ - □□ - □ - □ - □□ - □□ - □ - □□ - □ - □ - □										

HVH Horizontal or Vertical Discharge Blower Heater											Part Code	Description
Code kW											1	Motor
02	2.6 kW	12	12.5 kW	35	33.3 kW						2	Fan Blade
04	4.0 kW	15	15.0 kW	40	37.5 kW						3	Heating Element
05	5.0 kW	20	19.8 kW	45	45.0 kW						4	Element Contactor
07	7.5 kW	25	25.0 kW	50	50.0 kW						5	Control Transformer
10	10.0 kW	30	30.0 kW								6	Fan Only Switch
Code Volts											7	Time Delay Relay
2	240V	A	220V								8	Thermostat
4	480V	B	380V								9	Disconnect Switch
6	600V	C	400V								10	Thermostat Knob Only
7	277V	D	415V								11	Pilot Light
8	208V										12	Outlet Screen
Code Phase											13	High Limit, Automatic Reset
1	1										14	Fuse
3	3										15	Mounting Bracket
Code Control												
00	No Contactor											
30	Contactor with 24V Transformer											
31	Contactor with 24V Externally Supplied											
32	Contactor with 120V Transformer											
33	Contactor with 120V Externally Supplied											
34	Contactor with 208/240V Internally Supplied											
35	Contactor with 277V Internally Supplied											
Code Integral Thermostat												
0	None											
45	40-100°F Range (4° to 38°C)											
Code Disconnect Switch												
O	None											
D	Yes											
Code Fan Only Switch												
00	None											
FI	Internal (In Heater)											
FE	External (On Wall)											
Code Time Delay (Standard on 20kW and above)												
0	None											
R	Yes											
Code Pilot Light												
0	None											
P	Yes											
Code Outlet Screen												
0	None											
S	Yes											
HVH	05	2	1	34	TL	D	FI	-0	-0	-0	Typical Model Number	

When ordering HVH heaters, specify the model number and corresponding PCN (Product Code Number). If controls (thermostat, fan switch, transformer, disconnect) or other options are required, designate these options in the model number when ordering, as shown below. Always specify voltage, phase and kW by listing them on the purchase order specifications.

Limited Warranty:

Please refer to the Chromalox limited warranty applicable to this product at <http://www.chromalox.com/customer-service/policies/termsofsale.aspx>.

Chromalox, Inc.
 2150 N. Rulon White Blvd. • Odgen, UT 84404
 1-800-368-2493 • www.chromalox.com



Importado y distribuido en Chile por:
 Safe Energy Spa
www.safe-energy.cl